

**HALLIBURTON**



# Statoil Gravel Pack Tests Sum-up

Oddbjørn Larsen, Snr. Engineer Comp. Technology, Statoil

# Content

- Gravel Packing of Blank Pipe Sections
- Gravel as Zonal Isolation
- Gravel Packing past Swell Packers
- Increased Focus on Optimal Annulus Ratio
- Development of Scaled Down "Mini Model" Test Rig
- Questions

# Gravel Packing of Blank Pipe Sections

- First Statoil horizontal gravel packed well with blank section between screens completed on the Heidrun field in 2002
  - Expected  $\alpha$ -wave over the full length followed by  $\beta$ -waves over the screen sections only

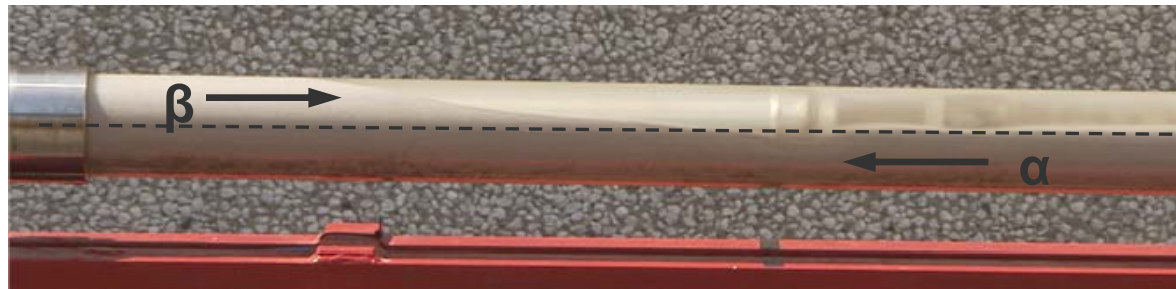

→ Achieved a total efficiency of ~90 % - How?

- Longest blank sections gravel packed to date, all Heidrun:

Well	OH angle [deg]	OH Length - Top screen to TD [m]	Length blank pipe section(s) between screen intervals [m]	GP Efficiency (gauge hole) [%]
A-44A	75 - 88	681	164 + 300	99
A-34AT2	90	615	225	> 100
A-50A	70 - 91	967	655 + 32	> 100

# Gravel Packing of Blank Pipe Sections

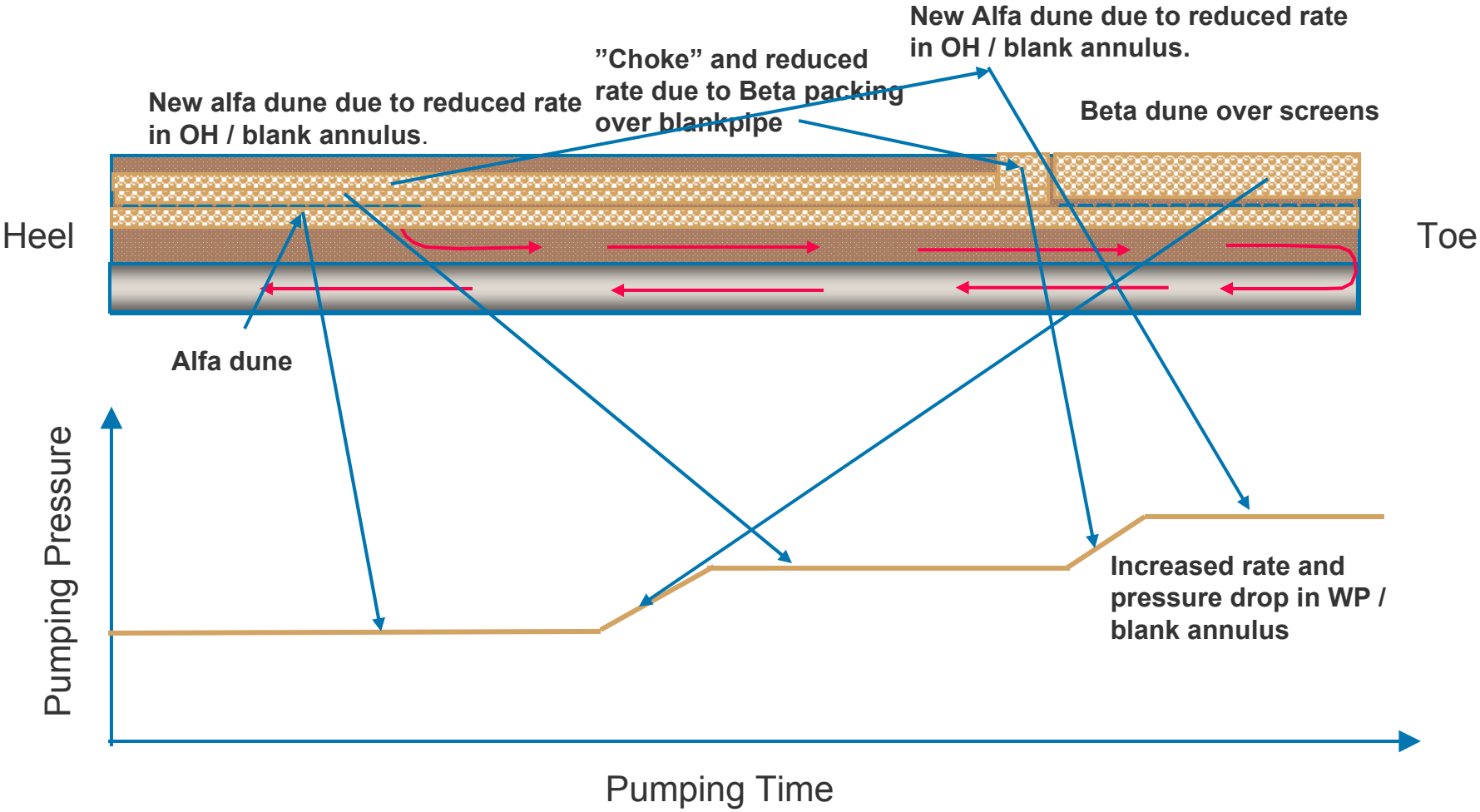

# Gravel as Zonal Isolation – Yard Tests

- 36 meter 9 5/8” casing rig
- 2 ea 5 1/2” screens with blank pipe in between
- Zonal isolation test by injecting water post gravel pack test

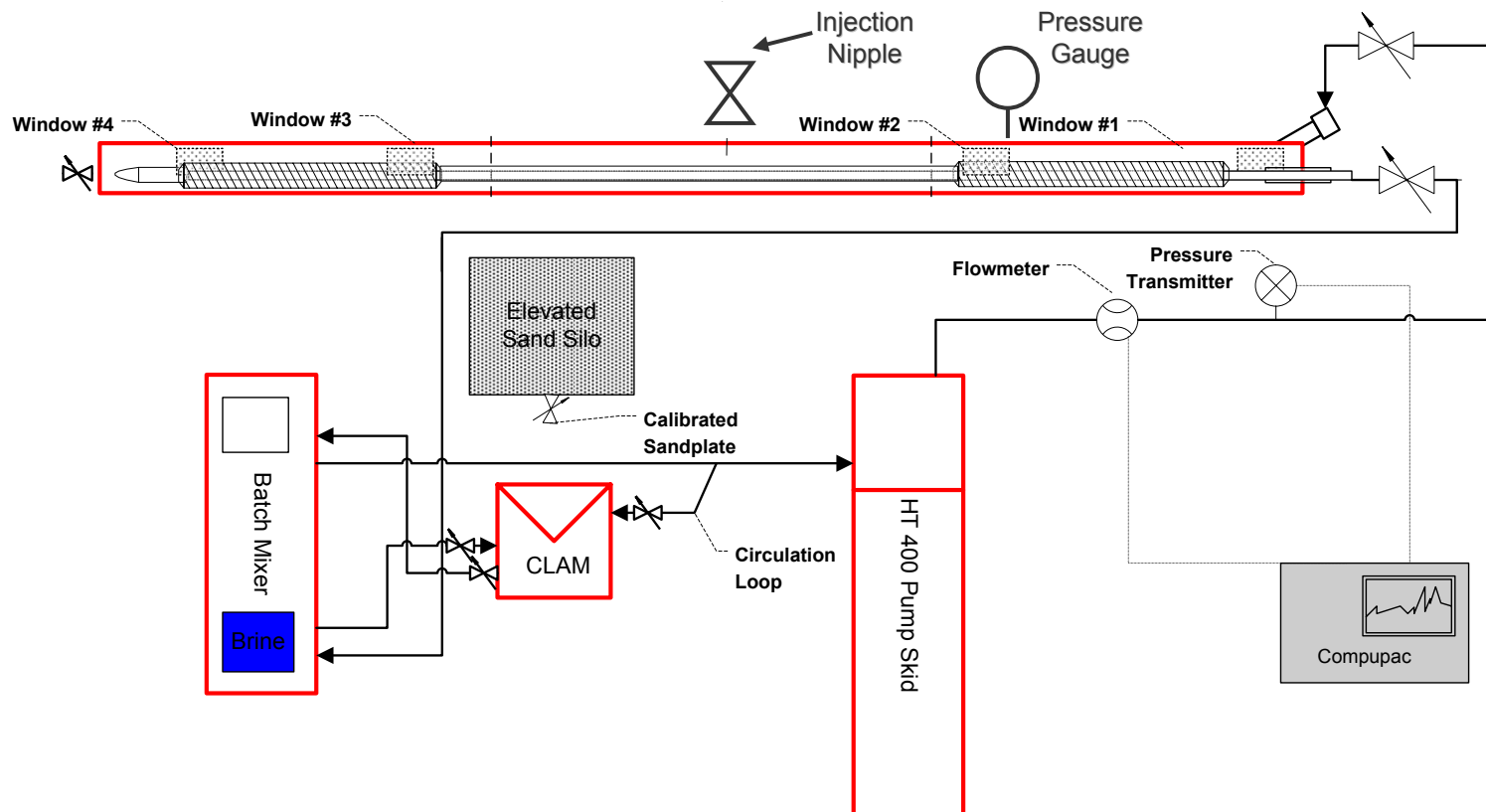

# Gravel as Zonal Isolation – Yard Tests



#	ID OH [in]	OD screens [in]	OD basepipe. [in]	ID screens [in]	Gravel Cons. [kg /m3]	Min. rate for gravel transport [lpm] / [m3/day]	Maks. rate [lpm]/ [m3/day]	<b>Max Pressure (bar)</b>
1	8.76	6	5.5	4.9	82	15 / 22	30 / 43	<b>6.5</b>

# Gravel as Zonal Isolation

Shutting off a water producing zone with a mechanical plug (or a straddle to avoid shutting off toe production)

- Tests show that **~0.13 m/s** is needed for 0.3 mm sand grains to start rolling

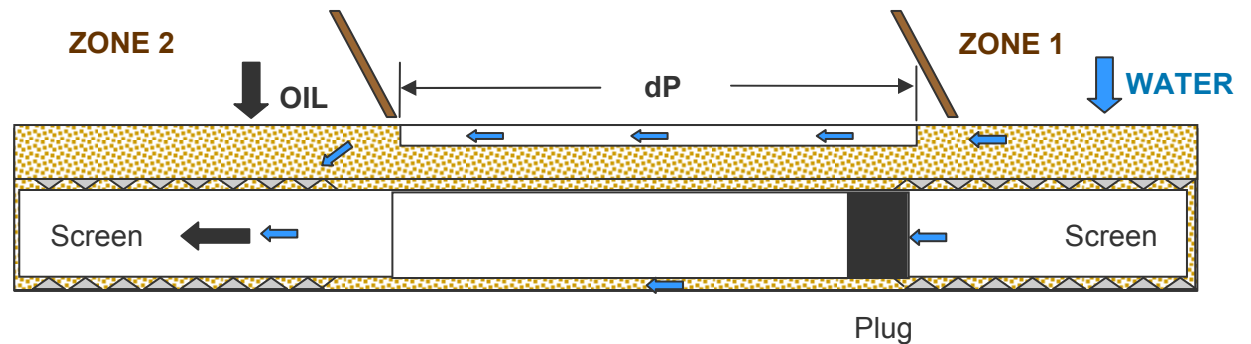

- 23 m<sup>3</sup>/day water production sufficient to create plug of gravel

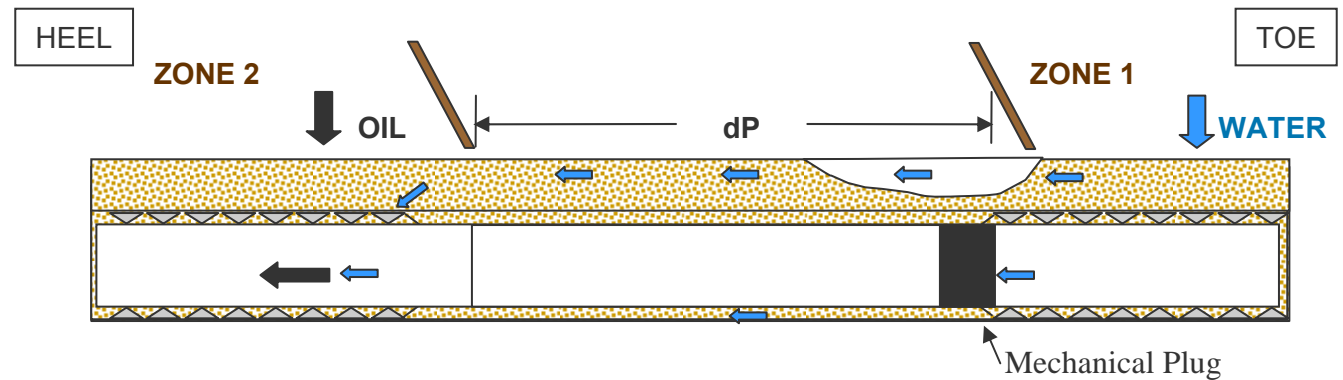

Darcy Calculation:

$$\Delta p = \underbrace{\frac{Q \times \mu \times l}{k \times A}}_{\text{Linear}} + \underbrace{\beta \times v^2 \times \rho \times l}_{\text{Turbulent}}$$

Production, Q [lpm] / [m <sup>3</sup> /d]	dp [bar] Water
30 / 43	5.8

# Gravel Packing past Swell Packers - Experience

- A bit of luck on the Heidrun field
  - Success with 7.9" SP, 5 ½" screens and 4" WP in 8 ½" OH
- A wake up on the Norne field
  - Early screen out with 8 ¼" SP, 7" screens and 5" WP in 9 ¼" OH

→ Velocity higher than without swell packer,  
but what about flow distribution?

- For the next Norne well yard tests were performed

— Achieved success increasing to 5 ½" WP

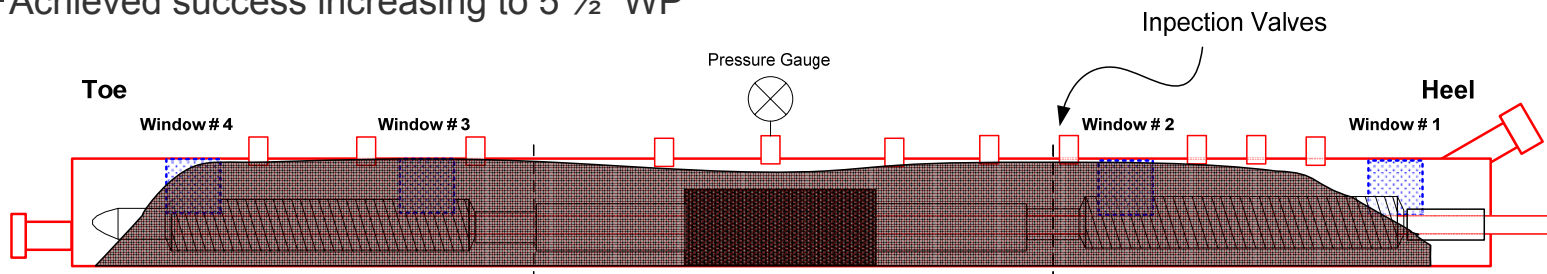

# Optimal Annulus Ratio and Transport Velocity

## - Increased Focus

**Preferred:**

— **Annulus ratio**

- $A/a > 2$

— **Velocity**

- $v > 0.8 \text{ m/s}$

**→ If not – GO TEST!**

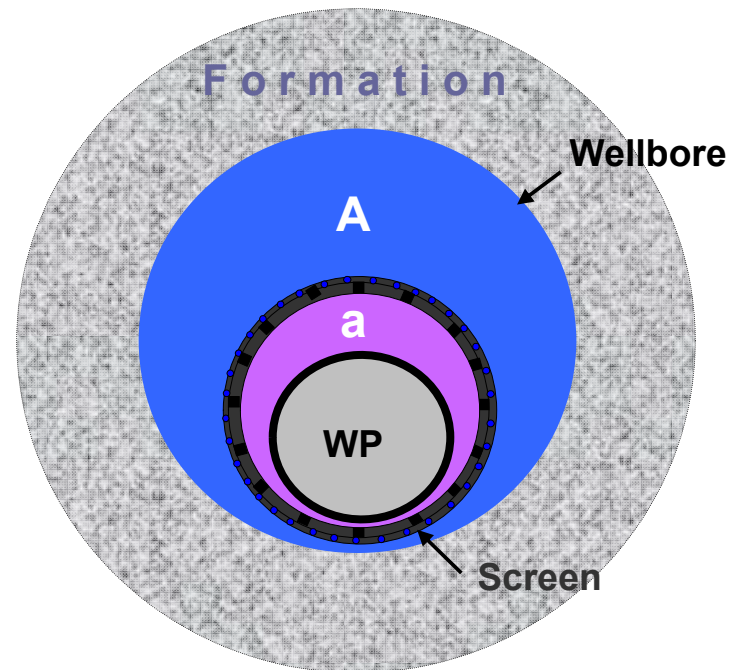

**Both parameters effect the other;**

a 'bad' annulus ratio can be compensated

by a higher velocity and vice versa

# Gravel Packing past Swell Packers - Experience

- A bit of luck on the Heidrun field

- Success with 7.9" SP, 5 ½" screens and 4" WP in 8 ½" OH

(A/a = 1.1, v = 1.75 m/s)

- A wake up on the Norne field

- Early screen out with 8 ¼" SP, 7" screens and 5" WP in 9 ¼" OH

(A/a = 1.33, v = 1.1 m/s)

→ Velocity higher than without swell packer,  
but what about flow distribution?

- For the next Norne well yard tests were performed

(A/a = 2.2, v = 1.75 m/s)

- Achieved success increasing to 5 ½" WP

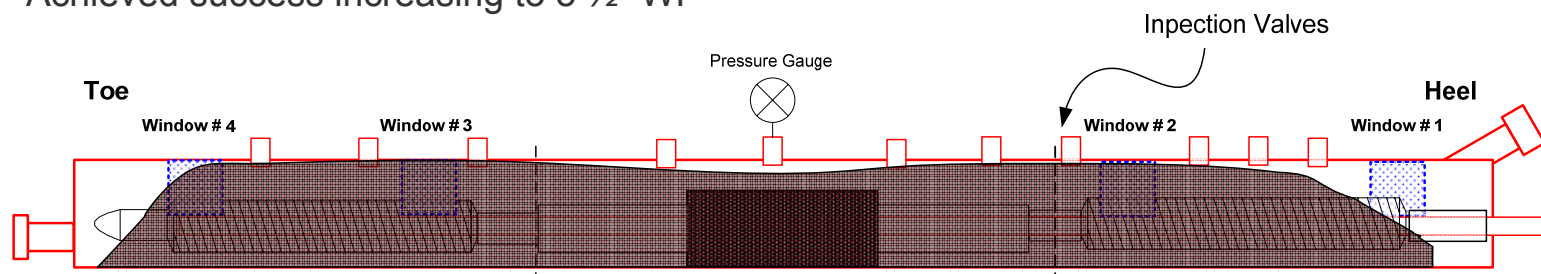

# Development of Scaled Down "Mini Model" Test Rig

- Scaled down with focus on **annulus ratios,  $A/a$** 
  - ➔ Expecting the same flow split between annuli as full scale
- Scaled down with focus on choosing the right **rate**, ensuring same slurry **velocity** as full scale
  - ➔ Experiencing the same settling scenario as full scale
- Scaled down ~2.5 times
  - 3 ¾" OH, 2" screens, **variable WP**
- **Main benefits:**
  - **CHANGING WP ONLY**
  - Significantly reduced cost
  - Several tests per day
  - High degree of visibility



# Mini Model Test Rig

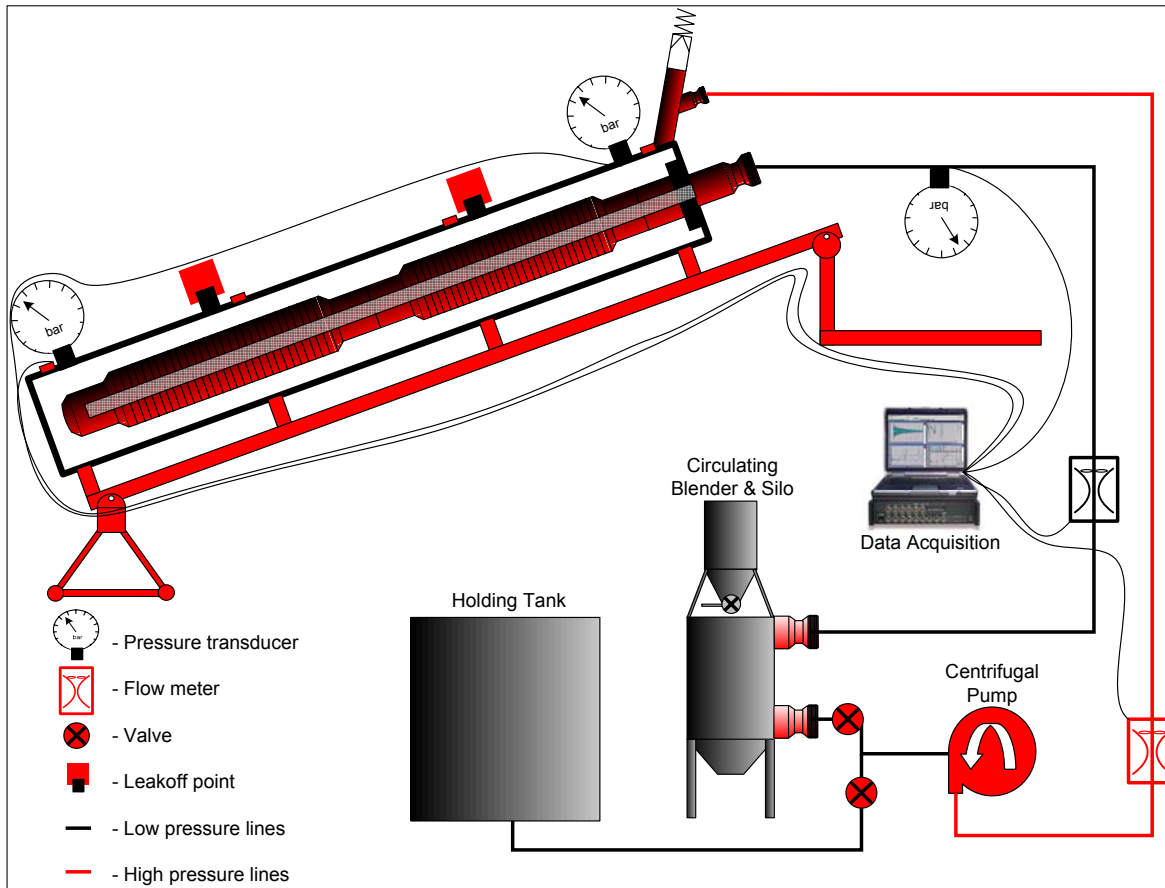

• Rig up

• Deviated

# Tests Done in the Mini Model

- **Several different configurations, rates, brines, gravel, gravel concentrations, etc.**
- **Swell packers**
- **Long blank sections**
- **ICD screens**
- **WBM, LSOBM and solids free OB mud as carrier fluids**
- **Critical angles around  $\pm 65$  degrees**
- **CAPS – Concentric Annular Path System**



# Thank you - Questions?

## Statoil Gravel Pack Tests Sum-up

Oddbjørn Larsen  
Snr Engineer Well Technology  
odda@statoil.com, tel: +47 95 11 15 08  
www.statoil.com

**HALLIBURTON**

